

Automatic Filtration Unit

System KBF

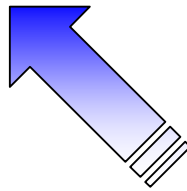
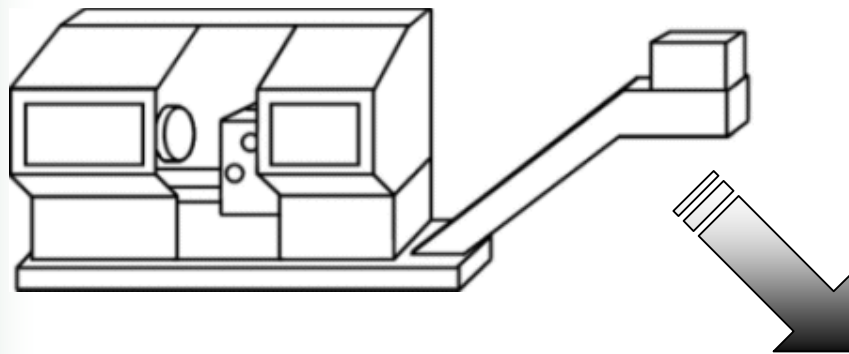

Filtrates fully automatic solid particles such as grinding sediments, forging scales, sludge etc. from:

- coolant used in machine tools and grinding machines
- centralized coolant treatment plants
- waste water plants etc.

Fully automatic filtration, system KBF using filtration paper

World-wide the most flexible filtration system due to the possibility of using different quality of filtration paper. This allows the user to achieve the desired results.

The filtration procedure takes place in a semi-circular shaped basin with a hydrostatic pressure of about 200 mm. Two disc wheels form the lateral sealing of the filtration basin. There are a number of scraper blades between the disc wheels which remove the waste from the drum and into the waste collector.

The filtration drum is centrally mounted with the inlet for the dirty liquid on the right hand side. The liquid passes the filter and is discharged over the full area downwards to the tank of the machine.

The filtration unit can optionally be equipped with take up reel for the dirty paper as well as with a stripper for the filter cake in order to separate paper and other waste.

The given filter efficiencies are to be seen as a guide only. Actual requirements of filter specification are calculated after taking into consideration all provided data.

Depending on throughput, medium, grade of filter paper, intake concentration, material and type of waste particles the appropriate filter is chosen.

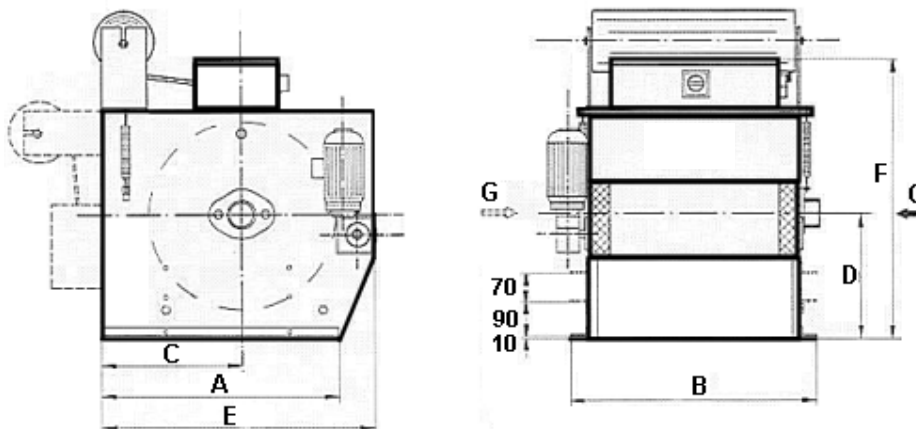

	KBF 452/500	KBF 452/710	KBF 802/710	KBF 802/1040
A	575	575	790	790
B	605	815	817	1130
C	340	340	505	505
D	300	300	460	460
E	665	665	1000	1000
F	675	675	1025	1025
G	DN 65	DN 65	DN 100	DN 100
Paper	500	710	710	1040
KW	0.09	0.09	0.13	0.13
Q = l/min.	max. 175	max. 250	max. 500	max. 750

Other products from our fabrication program:

- Oil separators with capacities from 75 l/h to 4800 l/h
- Emulsion treatment plants
- Combination oil separator / paper filter
- Combination oil separator / centrifuge
- Special units to customers requirements

