

Coolant Cleaner

QUICKSEP® 600

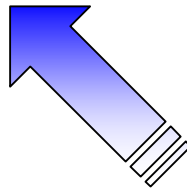
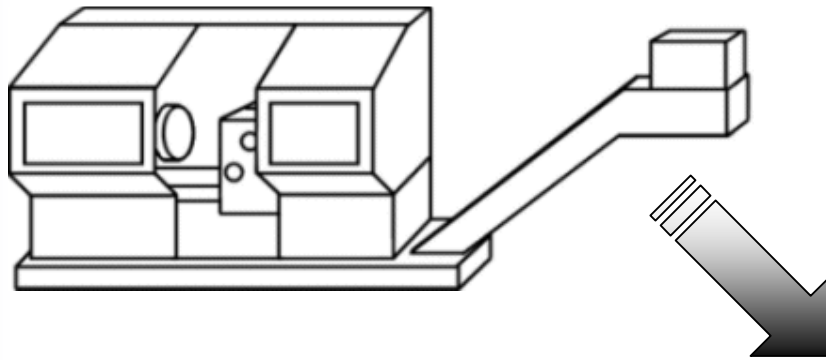

Separates oil from :

- soluble oils
- water
- industrial wash baths
- hardening baths
- degreasing baths

The consequent application of different physical laws in the separator type **QUICKSEP 600** as well as the optimal combination of the suction float and the pump is responsible for the very high separation efficiency of these units. The unwanted and free oils are thoroughly separated from all contaminated fluids such as metal cutting emulsions, wash baths, hardening baths etc. The clean medium from which the unwanted oils have been separated flows back to the treatment tank by gravity. The separation performance lies at over 98% when demulsifying fluids are used.

Except for the pump and the motor there are no moving parts within the oil separator **Quicksep 600**. Due to this fact maintenance costs are reduced to a minimum of rinsing the unit once or twice per year.

The standard execution of the oil separator **QUICKSEP 600** is delivered completely with oil tank with overflow protection, hydraulic dry run protection for the pump (eccentric "MONO"-type pump only), as well as feed and return tubes.

For the aspiration in emulsion tanks a variety of suction floats are available to suit specific requirements. A pre filter, air sparger under the filter media bed, air operated membrane pump etc. are available as options.

All units are built for ambient temperature. Special reinforced units for temperatures over 35°C up to 80°C are available on special request.

Technical data for stationary unit type QUICKSEP 600 (mobile execution as option):

Dimensions:	Width	1'200 mm	(without pre filter)
		1'500 mm	(with pre filter)
	Depth	700 mm	
	Height	1'400 mm	
Volume:		180 litres	
Net weight:		approx. 120 kg	
Pumping capacity nominal:		approx. 600 l/h	
Pumping capacity effective:		approx. 1200 l/h	
Drive:	electric	3x400 Volt, 1,1 kW	
	Option	Air operated membrane pump or peristaltic pump	

Accessories:

Suction floats:

Various standard floats are available ex stock. Specially designed floats to customers requirements can be manufactured on short turn.

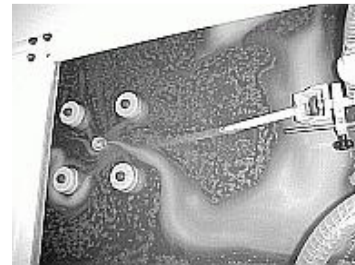

Pre filter:

Used for floating metal chips and other impurities. Filtration = 420 my.

Option: Magnetic separator in lid of pre filter.

