

Automatische Flachbett-Bandfilter

FM - FBF

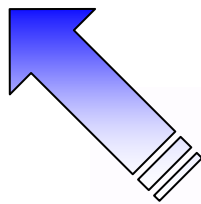
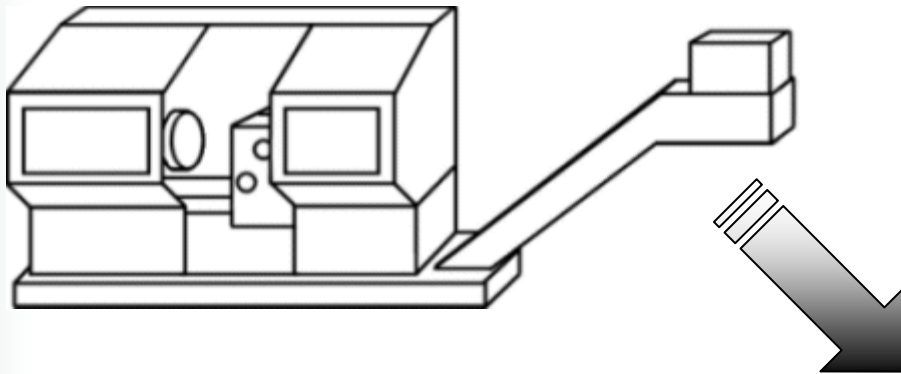

Filtriert vollautomatisch Feststoffe wie Schleifstaub, Gussabrieb, Schlamm etc. von:

- Kühlflüssigkeit in Tanks von Werkzeugmaschinen
- Zentralanlagen
- Abwasseraufbereitungsanlagen etc.

Technische Daten:

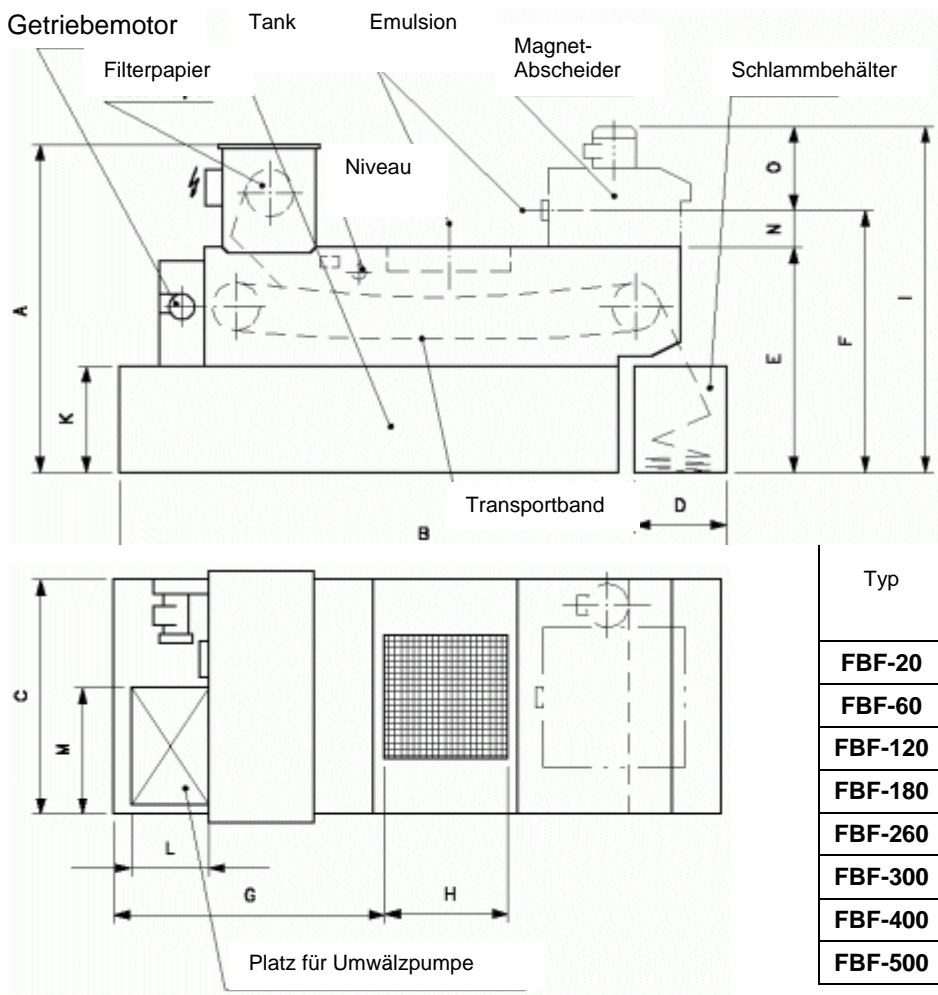

Typ	Leistung in l/min (Emulsion)	Volumen Emulsionstank (Grössere Behälter Option)	Mit Magnet-abscheider
FBF-20	20	50	-
FBF-60	60	120	FBF-60/MA
FBF-120	120	170	FBF-120/MA
FBF-180	180	255	FBF-180/MA
FBF-260	260	550	FBF-260/MA
FBF-300	300	1400	FBF-300/MA
FBF-400	400	1900	FBF-400/MA
FBF-500	500	2400	FBF-500/MA

Typ	A	B	C	D	E	F	G	H	I	K	L	M	N	O
FBF-20	485	890	380	200	335	-	490	130	-	185			-	-
FBF-60	626	1280	500	200	373	503	550	178	738	236	165	300	125	235
FBF-120	680	1630	577	300	430	555	770	250	790	220	220	400	125	235
FBF-180	680	1770	790	300	430	555	747	250	790	220	240	500	125	235
FBF-260	810	2334	790	320	560	685	1439	250	920	350	244	550	125	235
FBF-300	830	3700	1250	400	550/850	675	1070	400	910	350	300	900	125	235
FBF-400	830	4800	1250	400	550/850	675	1070	400	910	350	300	900	125	235
FBF-500	830	5900	1250	400	550/850	675	1070	400	910	350	300	900	125	235

